

## Multicolor Tuning of Lanthanide-Doped Nanoparticles by Single Wavelength Excitation

Feng Wang<sup>†,‡</sup> and Xiaogang Liu<sup>\*,†,‡</sup>

<sup>†</sup>Institute of Materials Research and Engineering, 3 Research Link, Singapore 117602

<sup>‡</sup>Department of Chemistry, Faculty of Science, National University of Singapore, Singapore 117543

**CONSPECTUS:** Lanthanide-doped nanoparticles exhibit unique luminescent properties, including large Stokes shift, sharp emission bandwidth, high resistance to optical blinking, and photobleaching, as well as the unique ability to convert long-wavelength stimulation into short-wavelength emission. These attributes are particularly needed for developing luminescent labels as alternatives to organic fluorophores and quantum dots. In recent years, the well-recognized advantages of upconversion nanocrystals as biomarkers have been manifested in many important applications, such as highly sensitive molecular detection and autofluorescence-free cell imaging. However, their potential in multiplexed detection and multicolor imaging is rarely exploited, largely owing to the research lagging on multicolor tuning of these particles.

Lanthanide doping typically involves an insulating host matrix and a trace amount of lanthanide dopants embedded in the host lattice. The luminescence observed from these doped crystalline materials primarily originates from electronic transitions within the  $[Xe]4f^n$  configuration of the lanthanide dopants. Thus a straightforward approach to tuning the emission is to dope different lanthanide activators in the host lattice. Meanwhile, the host lattice can exert a crystal field around the lanthanide dopants and sometimes may even exchange energy with the dopants. Therefore, the emission can also be modulated by varying the host materials. Recently, the advance in synthetic methods toward high quality core-shell nanocrystals has led to the emergence of new strategies for emission modulation. These strategies rely on precise control over either energy exchange interactions between the dopants or energy transfer involving other optical entities.

To provide a set of criteria for future work in this field, we attempt to review general and emerging strategies for tuning emission spectra through lanthanide doping. With significant progress made over the past several years, we now are able to design and fabricate nanoparticles displaying tailorable optical properties. In particular, we show that, by rational control of different combinations of dopants and dopant concentration, a wealth of color output can be generated under single-wavelength excitation. Strikingly, unprecedented single-band emissions can be obtained by careful selection of host matrices. By incorporating a set of lanthanide ions at defined concentrations into different layers of a core-shell structure, the emission spectra of the particles are largely expanded to cover almost the entire visible region, which is hardly accessible by conventional bulk phosphors. Importantly, we demonstrate that an inert-shell coating provides the particles with stable emission against perturbation in surrounding environments, paving the way for their applications in the context of biological networks.

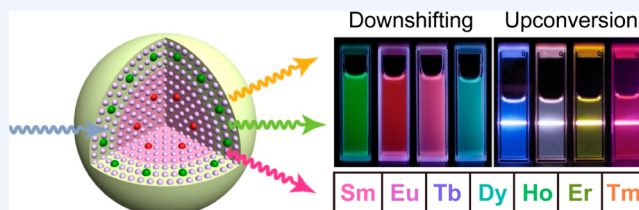

### 1. INTRODUCTION

The research on lanthanide-doped luminescent nanoparticles can be tracked back to more than a century ago, when the optical attractiveness of lanthanides was made known by Bunsen in spectroscopic study of “didymium sulfate” crystals.<sup>1</sup> Exploitation of lanthanide luminescence started in the 1960s on the basis of acquaintance with the fundamental theory, and the early works were mainly focused on bulk materials. The introduction of lanthanides into these solid materials laid the foundation for many modern applications, such as lighting, photonic communication, and battery devices.<sup>2–5</sup> During this period of time, considerable interest had arisen in screening various dopant/host combinations for improved optical properties.<sup>6</sup>

Lanthanide-doped nanoparticles emerged in the late 1990s due to the prevalent work on nanotechnology, marking a turning point in the landscape of modern lanthanide research.

Although the optical transitions in lanthanide-doped nanoparticles essentially resemble those in bulk materials, the nanostructure amenable to surface modifications provides new opportunities for research. Particularly, these nanoparticles are promising alternatives to molecular fluorophores for bioapplications.<sup>7–15</sup> Their unique optical properties, such as large Stokes shift and nonblinking, have enabled them to rival conventional luminescent probes in challenging tasks including single-molecule tracking and deep tissue imaging.<sup>16,17</sup> Despite the promising aspects of these nanomaterials, one urgent task that confronts materials chemists lies in the synthesis of nanoparticles with tunable emissions, which are essential for applications in multiplexed imaging and sensing.

Received: January 6, 2014

Published: March 11, 2014

Unlike the quantum dots exhibiting bandgap emission, lanthanide-doped nanoparticles are generally characterized by the emission of optical centers. Notably, the interaction between the optical centers, spatially confined within a single particle, exerts a strong influence on the emission profile of the particle. In this Account, we describe general chemical strategies for fine-tuning the optical emission of the nanoparticles. These include the control over doping concentration and host lattices. It is worth noting that although each lanthanide behaves differently and has different optical properties from all of the others, the lanthanides of different types can combine with one another to impart desired optical properties. It is this combination that accounts for the enormous variety of colors created by lanthanide doping. We also highlight recent advances in nanostructure fabrication by confining incompatible lanthanide dopants within different regions of a nanoparticle or by assembling different optical entities into a composite nanoparticle, providing powerful means to tune the particle emission.

## 2. MANIPULATING LANTHANIDE DOPANT

In theory, lanthanide-doped nanoparticles can be made to emit light at wavelengths that cover almost the entire visible spectrum by proper selection of dopants (or activators). These dopants have complex energy levels resulting from the enormous probability of distributing the electrons over the seven 4f orbitals. In practice, however, radiative emission can only be realized from a small number of energy levels characterized by a large gap separating the next lower-lying level. The large energy gap helps preserve the excitation energy against multiphonon relaxation.<sup>2</sup> Figure 1 illustrates main emitting levels and luminescent transitions of commonly used lanthanide activators.

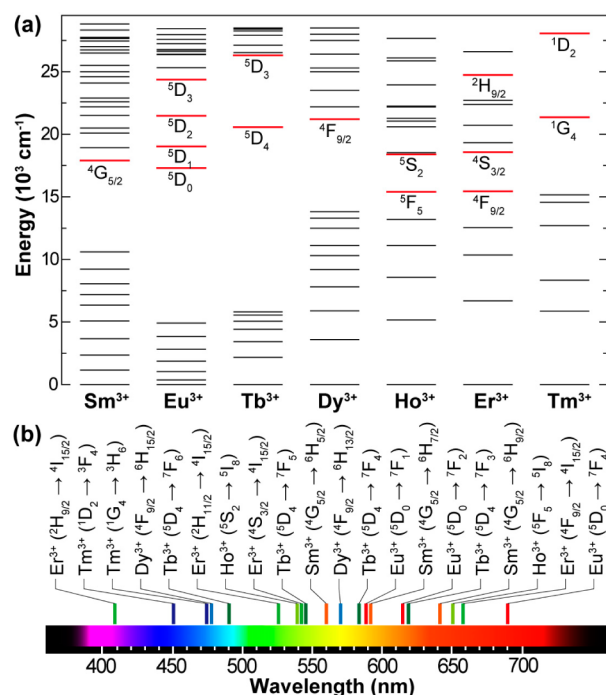

**Figure 1.** (a) Partial energy level diagram of lanthanides commonly used for multicolor tuning. Their typical emitting levels are highlighted in red. (b) Main luminescent transitions of the lanthanides in the visible part of the electromagnetic spectrum.

The intraconfigurational  $f-f$  transitions of lanthanide ions typically show low extinction coefficients on the order of  $1 \text{ M}^{-1} \text{ cm}^{-2}$  with narrow bandwidth. This attribute, together with the lack of fully matched absorption bands between different lanthanide ions, impedes effective excitation of different lanthanide activators under a single wavelength. A general solution to this problem is indirect excitation via a sensitizer, which serves as an antenna to collect the incident light and transfer it to the lanthanide activators (or emitters) non-radiatively. An array of optical entities including  $[\text{VO}_4]^{3-}$ ,  $\text{Bi}^{3+}$ , and  $\text{Ce}^{3+}$  featuring large absorption cross sections (typically through an allowed transition) can be used to sensitize Stokes-shifting lanthanide activators.<sup>18,19</sup> For anti-Stokes processes that convert long-wavelength excitation into shorter-wavelength emission, however, only  $\text{Yb}^{3+}$  serves as an efficient sensitizer to facilitate the stepwise energy transfer to different activators.<sup>20</sup> Note that  $\text{Gd}^{3+}$  is also frequently used as the sensitizer to enable excitation of different lanthanide ions under a single wavelength.<sup>21</sup> Table 1 lists typical optical sensitizers and their effectiveness in transferring the energy of absorbed light to lanthanide activators.

An early example of capitalizing on host sensitization was demonstrated by van Veggel and co-workers<sup>22</sup> in  $\text{LaVO}_4$  nanoparticles. They observed the energy transfer from the  $[\text{VO}_4]^{3-}$  host lattice to activators, resulting in tunable emission on ultraviolet (UV) excitation. In a parallel effort, Wang et al.<sup>23</sup> demonstrated downshifting multicolor tuning in  $\text{NaGdF}_4$  particles doped with  $\text{Tb}^{3+}$ ,  $\text{Eu}^{3+}$ ,  $\text{Dy}^{3+}$ , and  $\text{Sm}^{3+}$  as the activator, in conjunction with  $\text{Ce}^{3+}$  as the sensitizer (Figure 2a). A key advantage of this design is that the energy transfer from the sensitizer to the activator can be mediated by energy migration through Gd sublattice.

Since the energy levels of lanthanides are hardly affected by the embedding matrix, it has been challenging to fine-tune the emission wavelength. Typically, the emission color of nanoparticles is tuned by modulation of the multiplex emission of a lanthanide activator through control of dopant–dopant interaction in relation to dopant concentrations (Figure 3).<sup>24–28</sup> We previously demonstrated that the red-to-green emission ratio of  $\text{Er}^{3+}$  in  $\text{NaYF}_4:\text{Yb}/\text{Er}$  upconversion nanoparticles can be deliberately tuned by controlling back-energy-transfer from  $\text{Er}^{3+}$  to  $\text{Yb}^{3+}$  at different  $\text{Yb}^{3+}$  concentrations. We also show that the upconversion multicolor fine-tuning can be alternatively achieved by doping dual activators of  $\text{Er}^{3+}$  and  $\text{Tm}^{3+}$  at precisely defined concentration ratios (Figure 2b).<sup>26</sup> The versatility of the doping approach for fine-tuning emission colors was later confirmed by a number of research groups in a wide variety of host matrices incorporated with activator pairs of  $\text{Er}/\text{Tm}$ ,  $\text{Ho}/\text{Tm}$ , and  $\text{Eu}/\text{Tb}$ .<sup>29–32</sup> It is worth noting that the activator concentrations should be kept substantially low (<2 mol %) to minimize activator–activator interactions.

In search of dual emitters that do not cause deleterious cross-relaxations, we systematically studied downshifting  $\text{YVO}_4$  nanoparticles codoped with phosphorus and lanthanide ions to supply dual emissions.<sup>33</sup> We showed that the incorporation of phosphorus into the  $\text{YVO}_4$  particles results in intense blue emission from the  $[\text{VO}_4]^{3+}$  group, attributable to suppressed energy transfer from  $[\text{VO}_4]^{3+}$  to quenching sites. Upon further addition of lanthanides ( $\text{Eu}^{3+}$ ,  $\text{Dy}^{3+}$ , or  $\text{Sm}^{3+}$ ) into the  $\text{P}^{5+}$ -doped  $\text{YVO}_4$  particles, a second emission from the activator appears at the expense of the host emission. By varying the dopant concentration, the emission intensity balance between

Table 1. Typical Sensitizers Used in Nanoparticles for Transferring the Energy of Absorbed Light to Lanthanide Activators

sensitizer	absorption <sup>a</sup>	activator <sup>b</sup>							remarks	ref
		Sm <sup>3+</sup>	Eu <sup>3+</sup>	Tb <sup>3+</sup>	Dy <sup>3+</sup>	Ho <sup>3+</sup>	Er <sup>3+</sup>	Tm <sup>3+</sup>		
[VO <sub>4</sub> ] <sup>3-</sup>	250–350 nm (charge transfer)	+	+	–	+	+	+	+	Charge transfer quenching by Tb <sup>3+</sup>	22, 33
Ce <sup>3+</sup>	250–450 nm (4f–5d)	+	–	+	+				Charge transfer quenching by Eu <sup>3+</sup>	48
Gd <sup>3+</sup>	275 nm (4f–4f)	+	+	+	+				Capable of transferring energy via energy migration	24, 52
Yb <sup>3+</sup>	980 nm (4f–4f)						+	+	Commonly used for upconversion	20

<sup>a</sup>Absorption wavelength may change in different host matrices. <sup>b</sup>+: sensitized emission. –: quenched emission.

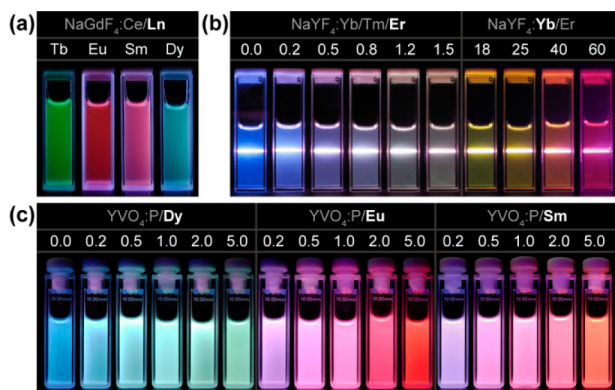

**Figure 2.** (a) Multicolor downshifting tuning of NaGdF<sub>4</sub> nanoparticles by varying activator compositions. (b) Multicolor upconversion tuning of NaYF<sub>4</sub> nanoparticles by varying the concentration of Er<sup>3+</sup> and Yb<sup>3+</sup>. (c) Multicolor downshifting tuning of YVO<sub>4</sub> nanoparticles by varying the concentrations of Dy<sup>3+</sup>, Eu<sup>3+</sup>, and Sm<sup>3+</sup>. Adapted with permission from refs 23 (Copyright 2007 IOP Publishing), 26 (Copyright 2008 American Chemical Society), and 33 (Copyright 2008 WILEY-VCH Verlag GmbH & Co. KGaA), respectively.

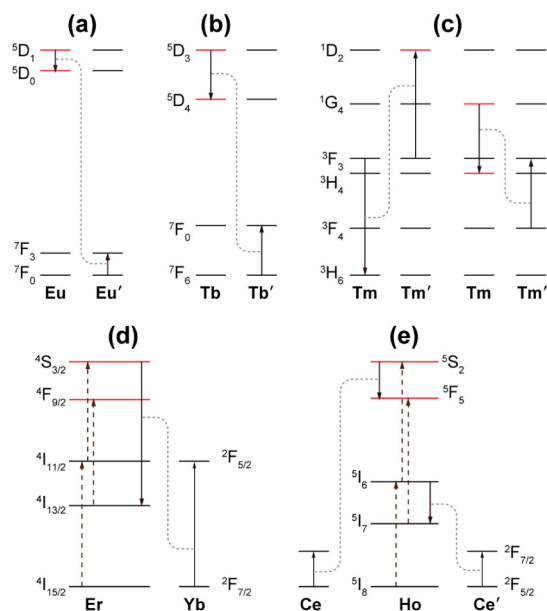

**Figure 3.** Typical energy transfer mechanisms used for emission tuning in lanthanide-doped materials. (a–c) The cross-relaxation between two lanthanides of the same sort enhances the luminescence emitted from a specific energy level of the ion (refs 24–26). (d, e) The cross-relaxation between different lanthanides modifies the excitation process, populating energy levels of the activator (refs 26 and 27). The main emitting levels are highlighted in red.

the [VO<sub>4</sub>]<sup>3+</sup> and lanthanides can be precisely controlled, allowing fine chromaticity tuning from blue to red (Figure 2c).

### 3. MANIPULATING HOST MATRIX

Apart from their predominant role in accommodating lanthanide dopants, host materials can directly alter the optical transitions of the dopants by exerting a crystal field and by subtracting the excitation energy of the dopants through lattice vibration. For nanostructured materials with a large portion of dopants enriched at the surface, additional factors, such as surface contaminations, must be taken into consideration as they can markedly influence the optical properties of the luminescent materials.

#### 3.1. The Effect of Host Structure

The f–f transitions of free lanthanide ions are strongly forbidden by the parity selection rule. When incorporated in a crystalline lattice, the uneven components of the crystal field can slightly mix odd-parity configurations into the [Xe]4f<sup>n</sup>. This mixing enables the f–f transitions to a certain extent depending on the symmetry of the crystal field and interacting strength of the crystal field with the lanthanides. Some f–f transitions are more sensitive to the crystal field than others. For example, the <sup>5</sup>D<sub>0</sub> → <sup>7</sup>F<sub>2</sub> emission line (~615 nm) of Eu<sup>3+</sup> is hypersensitive to the coordination environment, while the <sup>5</sup>D<sub>0</sub> → <sup>7</sup>F<sub>1</sub> emission line (~590 nm) is hardly affected by the surrounding matrix.<sup>34</sup> Accordingly, the emission intensity ratio of these two peaks can be adjusted using host matrices offering crystal sites of different symmetries for the lanthanides.

The host matrix has a drastic impact on upconversion luminescence. The variation in the host matrix will modify the excitation process in addition to affecting the emission transitions, leading to markedly different emission spectra. For example, the emission spectrum of Er<sup>3+</sup> in α-NaYF<sub>4</sub> is typically dominated by the <sup>4</sup>S<sub>3/2</sub> → <sup>4</sup>I<sub>15/2</sub> transition at ~660 nm, while in β-NaYF<sub>4</sub> the <sup>4</sup>F<sub>9/2</sub> → <sup>4</sup>I<sub>15/2</sub> transition at ~540 nm is more pronounced. Moreover, β-NaYF<sub>4</sub> offers Er<sup>3+</sup> emission with more than 4-fold higher efficiency than its cubic-phase counterpart.<sup>35</sup> It is believed that the phase-dependent emission is attributed to the varied site symmetry of lanthanide dopants in different host lattices.<sup>13</sup> Güdel and co-workers<sup>36</sup> suggested that the interaction of dopants located on two different lattice sites could also contribute to the intense emission of β-NaYF<sub>4</sub>. The presence of multiple lattice sites for lanthanides in NaYF<sub>4</sub> was later experimentally confirmed by Chen and co-workers through high-resolution photoluminescence spectroscopy.<sup>37</sup>

Based upon the learned knowledge of host structure-dependent luminescence, several groups have succeeded in tuning lanthanide emissions. In an intriguing recent demonstration, Hao and co-workers<sup>38</sup> showed that the structural symmetry of a ferroelectric host (BaTiO<sub>3</sub>) can be modified by applying a direct current bias voltage (Figure 4). Consequently, the emission spectrum of Er<sup>3+</sup> dopant was dynamically modulated under a sinusoidal alternating current bias, opening up new avenues for potential applications such as electrically controlled upconverters. On another matter, this approach may



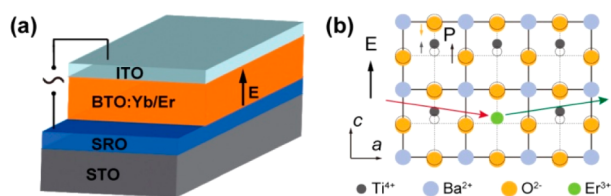
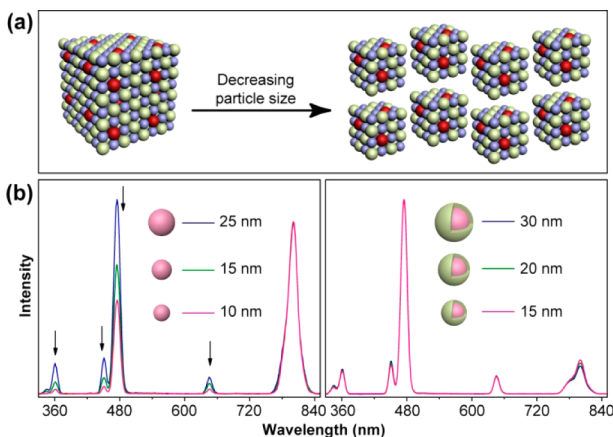

**Figure 4.** (a) The experimental setup used to modulate the upconversion emission of BaTiO<sub>3</sub>:Yb/Er thin film by electric field. (b) A schematic showing the electric-field-induced displacement of Ti<sup>4+</sup> and O<sup>2-</sup> ions which modifies the site symmetry of Er<sup>3+</sup> ion. Adapted with permission from ref 38. Copyright 2011 WILEY-VCH Verlag GmbH & Co. KGaA.

enable better understanding of the crystal-field effect on lanthanide luminescence because the site symmetry of the dopants can be systematically modulated in a single host material without the need for chemical composition modification.

### 3.2. The Effect of Particle Size

The effect of particle size on the luminescence intensity of lanthanide-doped nanoparticles can be harnessed for emission modulation.<sup>39–41</sup> It is important to note that this size-dependent optical property is most likely attributed to a surface quenching effect rather than the quantum confinement effect, a phenomenon typically observed in quantum dots. As the particle size decreases, the concentration of the surface dopants steadily increases (Figure 5a), leading to the variation in the overall emission spectrum.



**Figure 5.** The surface quenching effect on lanthanide luminescence. (a) A schematic showing increased surface lanthanides with decrease in particle size. (b) Emission spectra of different sized NaGdF<sub>4</sub>:Yb/Tm nanoparticles before and after shell modification (calc. 2.5 nm), respectively. Adapted with permission from ref 42. Copyright 2010 WILEY-VCH Verlag GmbH & Co. KGaA.

In 2010, our group reported a comparative spectroscopic investigation of a series of Yb/Tm codoped hexagonal-phase NaGdF<sub>4</sub> nanoparticles (10, 15, and 25 nm) with or without a thin surface protection layer.<sup>42</sup> We showed that the use of a thin layer coating largely preserves the optical integrity (relative emission intensities) of these nanoparticles (Figure 5b), thereby confirming the surface quenching effect on the size-dependent luminescence. By taking advantage of the surface quenching effect, other groups have also demonstrated upconversion emission tuning by tailoring the surface property

of the nanoparticles through ligand engineering or surface coating.<sup>43,44</sup>

### 3.3. The Effect of Host–Dopant Energy Transfer

Research has shown that a number of host matrices can exchange energy with lanthanide dopants, leading to tunable luminescence spectra of the dopants. For example, Mn<sup>2+</sup> ions in MnF<sub>2</sub>:Yb/Er and KMnF<sub>3</sub>:Yb/Er nanoparticles can strongly interact with Er<sup>3+</sup> ions to take away the excitation energy of Er<sup>3+</sup> in the <sup>4</sup>S<sub>3/2</sub> state. Subsequent energy transfer from Mn<sup>2+</sup> to Er<sup>3+</sup> increases the population of Er<sup>3+</sup> in its <sup>4</sup>F<sub>9/2</sub> state, resulting in an enlarged intensity ratio of red-to-green emission.<sup>45,46</sup> On the basis of these observations, we recently demonstrated a general method for the preparation of lanthanide-doped KMnF<sub>3</sub> nanoparticles showing strong single-band upconversion emission at ~660 nm.<sup>47</sup>

## 4. MANIPULATING PARTICLE INFRASTRUCTURE

Advances in the synthesis of nanoparticles have enabled the assembly of different luminescent centers into a single particle with well-defined interactions. The exquisite manipulation of compositional inhomogeneity at the nanoscale offers unprecedented control over the optical properties of the nanoparticles.

### 4.1. Confinement of Dopants

The selection of dopants for multicolor tuning in conventional bulk materials needs to meet stringent criteria because the extensive dopant–dopant interactions in the host lattice may induce luminescence quenching. In contrast, nanoscale manipulation of lanthanide-doped nanoparticles permits spatial confinement of dopants within a nanoscopic region. Significantly, this effect allows integration of otherwise optically incompatible dopants into a single nanoparticle with well-defined energy exchange interactions, thereby opening up new opportunities for multicolor tuning.

The standard strategy to spatially confining lanthanide dopants is to use a core–shell structure first demonstrated by Haase and co-workers<sup>48</sup> in 2003. In a follow-up study by Yi and Chow,<sup>49</sup> lanthanide dopants were completely confined in the core layer, and the shell layer was merely utilized to protect the dopants against surface quenchers (e.g., solvent molecules) for efficient luminescence process (Figure 6a). The effective use of core–shell structure to deliberately partition multiple types of lanthanide dopants (Figure 6b) was first reported in 2008 by Qian and Zhang,<sup>50</sup> who doped Yb/Tm and Yb/Er in core and shell layers of a NaYF<sub>4</sub>@NaYF<sub>4</sub> core–shell nanoparticle,

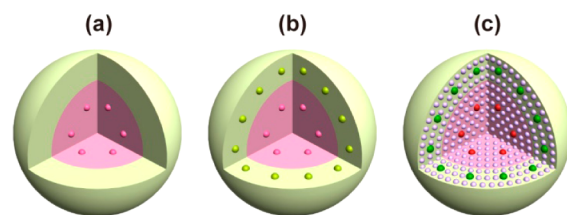

**Figure 6.** The general core–shell strategies for spatial confinement of lanthanide dopants in the host lattice of a nanoparticle. (a) The passive-shell coating design with the dopants merely incorporated in the core layer. (b) The active-shell coating design with different types of lanthanides separately doped in the core and shell layers. (c) The energy migration core–shell design featuring an optically active sublattice. Note that the shell uniformity and dopant distribution of experimental results may deviate from the ideal models depicted in the figure.

respectively. By controlling the dopant concentrations of  $\text{Tm}^{3+}$  and  $\text{Er}^{3+}$ , tunable emission colors were readily generated. In contrast to Yb/Tm/Er triply doped  $\text{NaYF}_4$  nanoparticles in which  $\text{Tm}^{3+}$  and  $\text{Er}^{3+}$  suffer from deleterious cross-relaxation, the active-shell coating design offers remarkably enhanced emission intensities of the activators due to suppressed energy exchange interactions between  $\text{Tm}^{3+}$  and  $\text{Er}^{3+}$ . The effect of core-shell structure on suppressing cross-relaxation has recently been explored by Zhang and co-workers<sup>51</sup> to inhibit the concentration quenching even at very high dopant concentrations.

In 2011, our group developed a core-shell nanoparticle having an optically active sublattice to induce distinct energy transfer through the core-shell interface (Figure 6c).<sup>52</sup> Our design involves the use of a  $\text{NaGdF}_4$ :Yb/Tm core coated with a  $\text{NaGdF}_4$  shell comprising common activators (Figure 7a). We

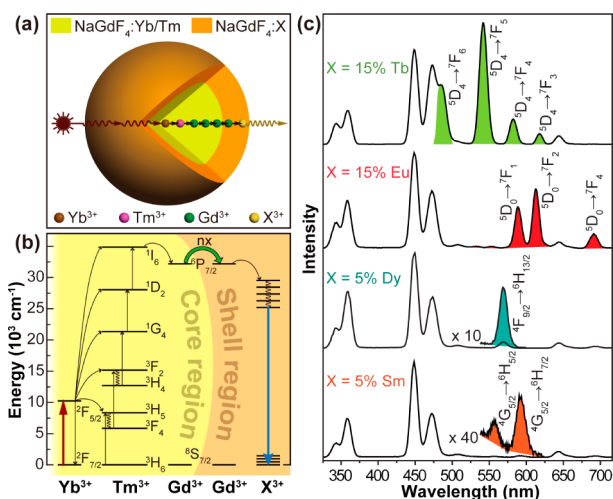

**Figure 7.** Energy migration-mediated upconversion (EMU) in core-shell nanoparticles. (a) Schematic design of a lanthanide-doped  $\text{NaGdF}_4$ @ $\text{NaGdF}_4$  nanoparticle for EMU (X: activator ion). (b) Proposed energy transfer mechanisms in the nanoparticle. Note that only partial energy levels of  $\text{Tm}^{3+}$  and  $\text{Gd}^{3+}$  are shown for clarity. (c) Emission spectra of the core-shell nanoparticles doped with different activators. Adapted with permission from ref 52. Copyright 2011 Macmillan Publishers Limited.

demonstrated that the Gd sublattice can initiate an energy migration process to bridge energy transfer through the core-shell interface (Figure 7b). This effect enables fine-tuning of upconversion emission for a wide range of lanthanide activators without long-lived intermediary energy states (Figure 7c), which are generally regarded as a prerequisite for photon upconversion. Although the concept of energy migration has been well documented in the past, previous studies typically involve the use of energy migration in bulk materials that generally feature a homogeneous mixing of the lanthanide dopants with the migrator ions in the host lattice. In these bulk systems, the energy exchange interactions between the lanthanides are complex and uncontrollable, thereby limiting effective utilization of the energy migration process. Very recently, the effect of energy migration in core-shell nanostructures was further developed with the inclusion of  $\text{Nd}^{3+}$  ions that enable tunable upconversion emission by biocompatible 800 nm excitation.<sup>53–55</sup>

## 4.2. Assembly of Particle Building Blocks

The assembly of optical nanoparticles of different chemical properties into one composite particle may lead to potentially synergistic optical properties as a result of controlled interplay between the constituent entities. This approach adds an additional dimension to multicolor tuning.

In 2008, Zhang and co-workers<sup>56</sup> carried out the research on coupling lanthanide-doped upconversion nanoparticles with conventional luminescent nanomaterials. In their work,  $\text{NaYF}_4$ :Yb/Er (or Tm) nanoparticles served as platform for the growth of a mesoporous silica shell impregnated with either organic dyes or quantum dots. Upon excitation at 980 nm, the lanthanide activators give rise to upconverted emission that can be partially transferred to the guest optical entities encapsulated in the silica shell through Förster resonance energy transfer (FRET). Consequently, a dual emission with controllable intensity balance is achieved (Table 2a). In parallel developments, several other groups have combined lanthanide-doped nanoparticles with a variety of dye molecules and quantum dots via widely different chemical approaches, including covalent bonding, surface polymerization, and thermal annealing.<sup>57–59</sup> For example, Yan et al.<sup>57</sup> developed the synthesis of CdSe- $\text{NaYF}_4$ :Yb/Er heterostructures that offer both sub-bandgap photoconductivity and tunable photoluminescence (Table 2b).

Although organic dyes and quantum dots offer improved emission tunability, they may raise new concerns over photostability and toxicity. In addition, when time-resolved luminescence techniques are used, the emission of dye molecules and quantum dots can be completely attenuated owing to their substantially shorter lifetime (on the order of nanoseconds) than that of lanthanide ions (up to several milliseconds).<sup>9</sup> On a separate note, some fundamental aspects of these luminescent composites still lack sufficient understanding. For example, Morgan et al.<sup>60</sup> suggested that radiative reabsorption (second excitation) might also contribute to the energy transfer from the lanthanide ions to the dye molecules (or quantum dots) although it is generally believed that FRET mediates the optical interaction. Indeed, time-resolved measurements are necessarily needed in future studies to resolve the role of radiative reabsorption and FRET in such systems.

Lanthanide-doped nanoparticles of different compositions have also been assembled for multicolor encoding. A representative example was demonstrated by Zhang and co-workers,<sup>61</sup> who encapsulated  $\text{NaYF}_4$ :Yb/Er and  $\text{NaYF}_4$ :Yb/Tm nanoparticles (~25 nm) in polystyrene beads (Table 2c). By changing the molar ratio between the particles, the emission colors were deliberately tuned from green to blue. Our group also found that ligand-free  $\text{NaGdF}_4$  nanoparticles can be readily absorbed by polystyrene microbeads upon mixing in butanol.<sup>52</sup> Different emission colors of the resulting hybrid microbeads can be clearly distinguished using a conventional microscope. Li and co-workers<sup>62</sup> have developed an interesting method to form binary superstructures with dual-mode luminescence properties through self-assembly of two sets of nanoparticles that respectively respond to UV and NIR excitation (Table 2d).

Metallic nanoparticles have also been coupled to lanthanide-doped nanoparticles for optical modulation. Metal nanoparticles in these nanocomposites typically do not emit light. Instead, they provide surface plasmons that could modify the local electromagnetic environment of lanthanide ions, potentially leading to the enhancement in luminescence emission of the lanthanides. For example, Duan and co-workers<sup>63</sup> observed

Table 2. Typical Strategies for Integration of Different Optical Properties

Building blocks & effects	Assembling approach *		Remarks
<p><b>Energy Transfer</b></p> <p>Lanthanide-doped nanoparticle</p> <p>Chromophore (dye, quantum dot)</p>	a)	b)	<p>(a) Chromophores are encapsulated into the silica shell layers of the lanthanide-doped nanoparticle.</p> <p>(b) The lanthanide-doped nanoparticle acts as supporting substrate for seeded growth of quantum dots.</p>
<p><b>Optical Encoding</b></p> <p>Lanthanide-doped nanoparticle (I)</p> <p>Lanthanide-doped nanoparticle (II)</p>	c)	d)	<p>(c) Lanthanide-doped nanoparticles of different compositions are incorporated into a polystyrene bead.</p> <p>(d) Different lanthanide-doped nanoparticles self-assemble to form a nanoparticle superstructure.</p>
<p><b>Plasmonic Modulation</b></p> <p>Lanthanide-doped nanoparticle</p> <p>Metal nanoparticle (gold, silver)</p>	e)	f)	<p>(e) The lanthanide-doped nanoparticle serves as supporting template for seeded growth of metal nanoparticles.</p> <p>(f) Metal nanoparticles are coupled to the lanthanide-doped nanoparticle through use of a thin silica layer.</p>

\* The assembling method involves the use of extra reagents including monomers (i.e. TEOS), emulsifiers (i.e. CTAB), and bi-functional linkers (i.e. EDTA). TEOS, CTAB, EDTA refer to tetraethyl orthosilicate, cetyltrimonium bromide, ethylenediaminetetraacetic acid, respectively.

a 2.5-fold increase in emission intensity of NaYF<sub>4</sub>:Yb/Tm upconversion nanoparticles after being coated with gold nanoparticles (Table 2e).

To deliberately control the plasmon field, engineered plasmonic surfaces have been developed as novel substrates to enhance the luminescence of lanthanides.<sup>64,65</sup> When compared with colloidal metal nanoparticles, 2D plasmonic substrates permit precise control over the nature and spatial distribution of the plasmonic “hot spots”. An excellent example was demonstrated by May and co-workers,<sup>66</sup> who specifically designed a gold film with nanopillar features to match the excitation frequency of NaYF<sub>4</sub>:Yb/Er nanoparticles at 980 nm. According to their simulations by the full-wave 3D finite difference time domain method, the engineered gold surface could offer an 11-fold amplification of excitation intensity relative to a smooth gold surface. The strong surface plasmon absorption of the metal nanoparticles in the visible spectral region may also lead to luminescence quenching. For example, Li et al.<sup>67</sup> reported the coating of silica-modified NaYF<sub>4</sub>:Yb/Er nanoparticles with gold nanoparticles (Table 2f). The authors found that the presence of gold nanoparticles strongly suppressed the emission of Er<sup>3+</sup> at 540 nm. Despite the achievement, additional studies on the light scattering effect and excited state dynamics are required for a thorough understanding of the mechanism underlying the luminescence enhancement.

In addition to metal nanoparticles, other types of optical materials including metal ions, metal oxides, and graphene have also been used to quench the luminescence of lanthanide-doped nanoparticles.<sup>68–70</sup> Despite their usefulness as alternative means for multicolor tuning, these methods typically result in hybrid nanomaterials with weakened emissions unsuitable for bioimaging applications. Nevertheless, these nanomaterials can be utilized for enabling promising applications in metal ion or biomolecular sensing by taking advantage of the nonauto-fluorescent assays and the large anti-Stokes shifts offered by the lanthanide-doped nanomaterials.<sup>69</sup>

## 5. CONCLUSIONS

The manipulation of lanthanide-doped nanoparticles, through precise control over doping concentration and composition as well as interfacial properties, allows the encoding of optically incompatible dopants or the incorporation of foreign entities suitable for unprecedented optical tuning. Considering the substantial flexibility in regulating the interaction between the lanthanide dopants in nanostructures, these lanthanide-doped nanoparticles may evolve into a new class of materials with extremely high designability and tunability. The challenges for future development in the field include improving luminescence efficiency of ultrasmall particles and developing nanoparticles with broadband excitation, which will certainly expand the range of their practical applications and commercialization in life science.

## AUTHOR INFORMATION

### Corresponding Author

\*E-mail: chmlx@nus.edu.sg.

### Funding

This work was supported by the A\*STAR, the Singapore-MIT Alliance, and the Singapore Ministry of Education.

### Notes

The authors declare no competing financial interest.

### Biographies

**Feng Wang** obtained his BE and PhD degrees in Materials Science and Engineering from Zhejiang University, China. He then carried out postdoctoral research work at the National University of Singapore and the Institute of Materials Research and Engineering in Singapore. He joined the faculty of the City University of Hong Kong in 2012. His current research focuses on the synthesis, spectroscopic investigation, and application of luminescent nanomaterials.

**Xiaogang Liu** earned his BE degree in Chemical Engineering from Beijing Technology and Business University, China. He received his MS degree in Chemistry from East Carolina University and completed



his PhD at Northwestern University. He then worked as a postdoctoral fellow at MIT for two years before joining the faculty of the National University of Singapore. He holds a joint appointment with the Institute of Materials Research and Engineering. His interests include nanomaterials synthesis, supramolecular chemistry, and surface science for catalysis, sensors, and biomedical applications.

## REFERENCES

- (1) Werts, M. H. V. Making sense of lanthanide luminescence. *Sci. Prog.* **2005**, *88*, 101–131.
- (2) Blasse, G.; Grabmaier, B. C. *Luminescent Materials*; Springer: Berlin, 1994.
- (3) Adam, J.-L. Lanthanides in non-oxide glasses. *Chem. Rev.* **2002**, *102*, 2461–2476.
- (4) Auzel, F. Upconversion and anti-Stokes processes with f and d ions in solids. *Chem. Rev.* **2004**, *104*, 139–174.
- (5) Bünzli, J.-C. G. Benefiting from the unique properties of lanthanide ions. *Acc. Chem. Res.* **2006**, *39*, 53–61.
- (6) Jüstel, T.; Nikol, H.; Ronda, C. New developments in the field of luminescent materials for lighting and displays. *Angew. Chem., Int. Ed.* **1998**, *37*, 3084–3103.
- (7) Wang, F.; Tan, W. B.; Zhang, Y.; Fan, X.; Wang, M. Luminescent nanomaterials for biological labelling. *Nanotechnology* **2006**, *17*, R1–R13.
- (8) Wang, F.; Liu, X. Recent advances in the chemistry of lanthanide-doped upconversion nanocrystals. *Chem. Soc. Rev.* **2009**, *38*, 976–989.
- (9) Wang, F.; Banerjee, D.; Liu, Y.; Chen, X.; Liu, X. Upconversion nanoparticles in biological labeling, imaging, and therapy. *Analyst* **2010**, *135*, 1839–1854.
- (10) Shen, J.; Sun, L.; Yan, C. Luminescent rare earth nanomaterials for bioprobe applications. *Dalton Trans.* **2008**, 5687–5697.
- (11) Zhou, J.; Liu, Z.; Li, F. Upconversion nanophosphors for small-animal imaging. *Chem. Soc. Rev.* **2012**, *41*, 1323–1349.
- (12) Mader, H. S.; Kele, P.; Saleh, S. M.; Wolfbeis, O. S. Upconverting luminescent nanoparticles for use in bioconjugation and bioimaging. *Curr. Opin. Chem. Biol.* **2010**, *14*, 582–596.
- (13) Achatz, D. E.; Ali, R.; Wolfbeis, O. S. Luminescent chemical sensing, biosensing, and screening using upconverting nanoparticles. *Top. Curr. Chem.* **2011**, *300*, 29–50.
- (14) Haase, M.; Schäfer, H. Upconverting nanoparticles. *Angew. Chem., Int. Ed.* **2011**, *50*, 5808–5829.
- (15) Yang, Y. Upconversion nanophosphors for use in bioimaging, therapy, drug delivery and bioassays. *Microchim. Acta* **2014**, *181*, 263–294.
- (16) Kobayashi, H.; Kosaka, N.; Ogawa, M.; Morgan, N. Y.; Smith, P. D.; Murray, C. B.; Ye, X.; Collins, J.; Kumar, G. A.; Bell, H.; Choyke, P. L. In vivo multiple color lymphatic imaging using upconverting nanocrystals. *J. Mater. Chem.* **2009**, *19*, 6481–6484.
- (17) Wu, S.; Han, G.; Milliron, D. J.; Aloni, S.; Altoe, V.; Talapin, D. V.; Cohen, B. E.; Schuck, P. J. Non-blinking and photostable upconverted luminescence from single lanthanide-doped nanocrystals. *Proc. Natl. Acad. Sci. U.S.A.* **2009**, *106*, 10917–10921.
- (18) Palilla, F. C.; Levine, A. K.; Rinkevics, M. Rare earth activated phosphors based on yttrium orthovanadate and related compounds. *J. Electrochem. Soc.* **1965**, *112*, 776–779.
- (19) Blasse, G.; Brill, A. Study of energy transfer from  $\text{Sb}^{3+}$ ,  $\text{Bi}^{3+}$ ,  $\text{Ce}^{3+}$  to  $\text{Sm}^{3+}$ ,  $\text{Eu}^{3+}$ ,  $\text{Tb}^{3+}$ ,  $\text{Dy}^{3+}$ . *J. Chem. Phys.* **1967**, *47*, 1920–1926.
- (20) Heer, S.; Kömpe, K.; Güdel, H. U.; Haase, M. Highly efficient multicolour upconversion emission in transparent colloids of lanthanide-doped  $\text{NaYF}_4$  nanocrystals. *Adv. Mater.* **2004**, *16*, 2102–2105.
- (21) De Vries, A. J.; Smeets, W. J. J.; Blasse, G. The trapping of  $\text{Gd}^{3+}$  excitation energy by  $\text{Cr}^{3+}$  and rare earth ions in  $\text{GdAlO}_3$ . *Mater. Chem. Phys.* **1987**, *18*, 81–92.
- (22) Stouwdam, J. W.; Raudsepp, M.; van Veggel, F. C. J. M. Colloidal nanoparticles of  $\text{Ln}^{3+}$ -doped  $\text{LaVO}_4$ : Energy transfer to visible- and near-infrared-emitting lanthanide ions. *Langmuir* **2005**, *21*, 7003–7008.
- (23) Wang, F.; Fan, X.; Wang, M.; Zhang, Y. Multicolor  $\text{PEI}/\text{NaGdF}_4:\text{Ce}^{3+}, \text{Ln}^{3+}$  nanoparticles by single wavelength excitation. *Nanotechnology* **2007**, *18*, 025701.
- (24) Su, Q.; Han, S.; Xie, X.; Zhu, H.; Chen, H.; Chen, C.-K.; Liu, R.-S.; Chen, X.; Wang, F.; Liu, X. The effect of surface coating on energy migration-mediated upconversion. *J. Am. Chem. Soc.* **2012**, *134*, 20849–20857.
- (25) Liu, Y.; Tu, D.; Zhu, H.; Li, R.; Luo, W.; Chen, X. A strategy to achieve efficient dual-mode luminescence of  $\text{Eu}^{3+}$  in lanthanides doped multifunctional  $\text{NaGdF}_4$  nanocrystals. *Adv. Mater.* **2010**, *22*, 3266–3271.
- (26) Wang, F.; Liu, X. Upconversion multicolor fine-tuning: Visible to near-infrared emission from lanthanide-doped  $\text{NaYF}_4$  nanoparticles. *J. Am. Chem. Soc.* **2008**, *130*, 5642–5643.
- (27) Chen, G.; Liu, H.; Somesfalean, G.; Liang, H.; Zhang, Z. Upconversion emission tuning from green to red in  $\text{Yb}^{3+}/\text{Ho}^{3+}$ -codoped  $\text{NaYF}_4$  nanocrystals by tridoping with  $\text{Ce}^{3+}$  ions. *Nanotechnology* **2009**, *20*, 385704.
- (28) Chan, E. M.; Han, G.; Goldberg, J. D.; Gargas, D. J.; Ostrowski, A. D.; Schuck, P. J.; Cohen, B. E.; Milliron, D. J. Combinatorial discovery of lanthanide-doped nanocrystals with spectrally pure upconverted emission. *Nano Lett.* **2012**, *12*, 3839–3845.
- (29) Wang, F.; Han, Y.; Lim, C. S.; Lu, Y.; Wang, J.; Xu, J.; Chen, H.; Zhang, C.; Hong, M.; Liu, X. Simultaneous phase and size control of upconversion nanocrystals through lanthanide doping. *Nature* **2010**, *463*, 1061–1065.
- (30) Wang, J.; Wang, F.; Xu, J.; Wang, Y.; Liu, Y.; Chen, H.; Chen, X.; Liu, X. Lanthanide-doped  $\text{LiYF}_4$  nanoparticles: Synthesis and multicolor upconversion tuning. *C. R. Chim.* **2010**, *13*, 731–736.
- (31) Li, F.; Li, N.; Wang, M.; Xu, S.; Zhang, H. Intense visible multicolored luminescence from lanthanide ion-pair codoped  $\text{NaGdF}_4$  nanocrystals. *Luminescence* **2010**, *25*, 394–398.
- (32) Sotiriou, G. A.; Schneider, M.; Pratsinis, S. E. Color-tunable nanophosphors by codoping flame-made  $\text{Y}_2\text{O}_3$  with Tb and Eu. *J. Phys. Chem. C* **2011**, *115*, 1084–1089.
- (33) Wang, F.; Xue, X.; Liu, X. Multicolor tuning of (Ln, P)-doped  $\text{YVO}_4$  nanoparticles by single-wavelength excitation. *Angew. Chem., Int. Ed.* **2008**, *47*, 906–909.
- (34) Stouwdam, J. W.; van Veggel, F. C. J. M. Near-infrared emission of redispersible  $\text{Er}^{3+}$ ,  $\text{Nd}^{3+}$ , and  $\text{Ho}^{3+}$  doped  $\text{LaF}_3$  nanoparticles. *Nano Lett.* **2002**, *2*, 733–737.
- (35) Krämer, K. W.; Biner, D.; Frei, G.; Güdel, H. U.; Hehlen, M. P.; Lüthi, S. R. Hexagonal sodium yttrium fluoride based green and blue emitting upconversion phosphors. *Chem. Mater.* **2004**, *16*, 1244–1251.
- (36) Aebischer, A.; Hostettler, M.; Hauser, J.; Krämer, K.; Weber, T.; Güdel, H. U.; Bürgi, H.-B. Structural and spectroscopic characterization of active sites in a family of light-emitting sodium lanthanide tetrafluorides. *Angew. Chem., Int. Ed.* **2006**, *45*, 2802–2806.
- (37) Tu, D.; Liu, Y.; Zhu, H.; Li, R.; Liu, L.; Chen, X. Breakdown of crystallographic site symmetry in lanthanide-doped  $\text{NaYF}_4$  crystals. *Angew. Chem., Int. Ed.* **2013**, *52*, 1128–1133.
- (38) Hao, J.; Zhang, Y.; Wei, X. Electric-induced enhancement and modulation of upconversion photoluminescence in epitaxial  $\text{BaTiO}_3:\text{Yb}/\text{Er}$  thin films. *Angew. Chem., Int. Ed.* **2011**, *50*, 6876–6880.
- (39) Vetrone, F.; Boyer, J. C.; Capobianco, J. A.; Speghini, A.; Bettinelli, M. Significance of  $\text{Yb}^{3+}$  concentration on the upconversion mechanisms in codoped  $\text{Y}_2\text{O}_3:\text{Er}^{3+}, \text{Yb}^{3+}$  nanocrystals. *J. Appl. Phys.* **2004**, *96*, 661–667.
- (40) Bai, X.; Song, H.; Pan, G.; Lei, Y.; Wang, T.; Ren, X.; Lu, S.; Dong, B.; Dai, Q.; Fan, L. Size-dependent upconversion luminescence in  $\text{Er}^{3+}/\text{Yb}^{3+}$ -codoped nanocrystalline yttria: saturation and thermal effects. *J. Phys. Chem. C* **2007**, *111*, 13611–13617.
- (41) Yin, A.; Zhang, Y.; Sun, L.; Yan, C. Colloidal synthesis and blue based multicolor upconversion emissions of size and composition controlled monodisperse hexagonal  $\text{NaYF}_4:\text{Yb}, \text{Tm}$  nanocrystals. *Nanoscale* **2010**, *2*, 953–959.
- (42) Wang, F.; Wang, J.; Liu, X. Direct evidence of a surface quenching effect on size-dependent luminescence of upconversion nanoparticles. *Angew. Chem., Int. Ed.* **2010**, *49*, 7456–7460.

- (43) Niu, W.; Wu, S.; Zhang, S. A facile and general approach for the multicolor tuning of lanthanide-ion doped NaYF<sub>4</sub> upconversion nanoparticles within a fixed composition. *J. Mater. Chem.* **2010**, *20*, 9113–9117.
- (44) Zhang, F.; Che, R.; Li, X.; Yao, C.; Yang, J.; Shen, D.; Hu, P.; Li, W.; Zhao, D. Direct imaging the upconversion nanocrystal core/shell structure at the subnanometer level: shell thickness dependence in upconverting optical properties. *Nano Lett.* **2012**, *12*, 2852–2858.
- (45) Zeng, J.; Xie, T.; Li, Z.; Li, Y. Monodispersed nanocrystalline fluoroperovskite up-conversion phosphors. *Cryst. Growth Des.* **2007**, *7*, 2774–2777.
- (46) Xie, M.; Peng, X.; Fu, X.; Zhang, J.; Li, G.; Yu, X. Synthesis of Yb<sup>3+</sup>/Er<sup>3+</sup> co-doped MnF<sub>2</sub> nanocrystals with bright red up-converted fluorescence. *Scr. Mater.* **2009**, *60*, 190–193.
- (47) Wang, J.; Wang, F.; Wang, C.; Liu, Z.; Liu, X. Single-band upconversion emission in lanthanide-doped KMnF<sub>3</sub> nanocrystals. *Angew. Chem., Int. Ed.* **2011**, *50*, 10369–10372.
- (48) Kömpe, K.; Borchert, H.; Storz, J.; Lobo, A.; Adam, S.; Möller, T.; Haase, M. Green-emitting CePO<sub>4</sub>:Tb/LaPO<sub>4</sub> core-shell nanoparticles with 70% photoluminescence quantum yield. *Angew. Chem., Int. Ed.* **2003**, *42*, 5513–5516.
- (49) Yi, G.-S.; Chow, G.-M. Water-soluble NaYF<sub>4</sub>:Yb,Er(Tm)/NaYF<sub>4</sub>/Polymer core/shell/shell nanoparticles with significant enhancement of upconversion fluorescence. *Chem. Mater.* **2007**, *19*, 341–343.
- (50) Qian, H.; Zhang, Y. Synthesis of hexagonal-phase core-shell NaYF<sub>4</sub> nanocrystals with tunable upconversion fluorescence. *Langmuir* **2008**, *24*, 12123–12125.
- (51) Liu, X.; Kong, X.; Zhang, Y.; Tu, L.; Wang, Y.; Zeng, Q.; Li, C.; Shi, Z.; Zhang, H. Breakthrough in concentration quenching threshold of upconversion luminescence via spatial separation of the emitter doping area for bio-applications. *Chem. Commun.* **2011**, *47*, 11957–11959.
- (52) Wang, F.; Deng, R.; Wang, J.; Wang, Q.; Han, Y.; Zhu, H.; Chen, X.; Liu, X. Tuning upconversion through energy migration in core-shell nanoparticles. *Nat. Mater.* **2011**, *10*, 968–973.
- (53) Wang, Y.; Liu, G.; Sun, L.; Xiao, J.; Zhou, J.; Yan, C. Nd<sup>3+</sup>-sensitized upconversion nanophosphors: Efficient in vivo bioimaging probes with minimized heating effect. *ACS Nano* **2013**, *7*, 7200–7206.
- (54) Xie, X.; Gao, N.; Deng, R.; Sun, Q.; Xu, Q.; Liu, X. Mechanistic investigation of photon upconversion in Nd<sup>3+</sup>-sensitized core-shell nanoparticles. *J. Am. Chem. Soc.* **2013**, *135*, 12608–12611.
- (55) Wen, H.; Zhu, H.; Chen, X.; Hung, T.; Wang, B.; Zhu, G.; Yu, S.; Wang, F. Upconverting near-infrared light through energy management in core-shell-shell nanoparticles. *Angew. Chem., Int. Ed.* **2013**, *52*, 13419–13423.
- (56) Li, Z.; Zhang, Y.; Jiang, S. Multicolor core/shell-structured upconversion fluorescent nanoparticles. *Adv. Mater.* **2008**, *20*, 4765–4769.
- (57) Yan, C.; Dadvand, A.; Rosei, F.; Perepichka, D. F. Near-IR photoresponse in new up-converting CdSe/NaYF<sub>4</sub>:Yb,Er nano-heterostructures. *J. Am. Chem. Soc.* **2010**, *132*, 8868–8869.
- (58) Gorris, H. H.; Ali, R.; Saleh, S. M.; Wolfbeis, O. S. Tuning the dual emission of photon-upconverting nanoparticles for ratiometric multiplexed encoding. *Adv. Mater.* **2011**, *23*, 1652–1655.
- (59) Su, L. T.; Karuturi, S. K.; Luo, J.; Liu, L.; Liu, X.; Guo, J.; Sum, T. C.; Deng, R.; Fan, H.; Liu, X.; Tok, A. I. Y. Photon upconversion in hetero-nanostructured photoanodes for enhanced near-infrared light harvesting. *Adv. Mater.* **2013**, *25*, 1603–1607.
- (60) Morgan, C. G.; Dad, S.; Mitchell, A. C. Present status of, and future prospects for, upconverting phosphors in proximity-based bioassay. *J. Alloys Compd.* **2008**, *451*, S26–S29.
- (61) Qian, H.; Li, Z.; Zhang, Y. Multicolor polystyrene nanospheres tagged with up-conversion fluorescent nanocrystals. *Nanotechnology* **2008**, *19*, 255601.
- (62) Li, P.; Peng, Q.; Li, Y. Dual-mode luminescent colloidal spheres from monodisperse rare-earth fluoride nanocrystals. *Adv. Mater.* **2009**, *21*, 1945–1948.
- (63) Zhang, H.; Li, Y.; Ivanov, I.; Qu, Y.; Huang, Y.; Duan, X. Plasmonic modulation of the upconversion fluorescence in NaYF<sub>4</sub>:Yb/Tm hexaplate nanocrystals using gold nanoparticles or nanoshells. *Angew. Chem., Int. Ed.* **2010**, *49*, 2865–2868.
- (64) Zhang, W.; Ding, F.; Chou, S. Y. Large enhancement of upconversion luminescence of NaYF<sub>4</sub>:Yb<sup>3+</sup>/Er<sup>3+</sup> nanocrystal by 3D plasmonic nano-antennas. *Adv. Mater.* **2012**, *24*, OP236–OP241.
- (65) Saboktakin, M.; Ye, X.; Chettiar, U. K.; Engheta, N.; Murray, C. B.; Kagan, C. R. Plasmonic enhancement of nanophosphor upconversion luminescence in Au nanohole arrays. *ACS Nano* **2013**, *7*, 7186–7192.
- (66) Paudel, H. P.; Zhong, L.; Bayat, K.; Baroughi, M. F.; Smith, S.; Lin, C.; Jiang, C.; Berry, M. T.; May, P. S. Enhancement of near-infrared-to-visible upconversion luminescence using engineered plasmonic gold surfaces. *J. Phys. Chem. C* **2011**, *115*, 19028–19036.
- (67) Li, Z.; Wang, L.; Wang, Z.; Liu, X.; Xiong, Y. Modification of NaYF<sub>4</sub>:Yb,Er@SiO<sub>2</sub> nanoparticles with gold nanocrystals for tunable green-to-red upconversion emissions. *J. Phys. Chem. C* **2011**, *115*, 3291–3296.
- (68) Saleh, S. M.; Ali, R.; Wolfbeis, O. S. Quenching of the luminescence of upconverting luminescent nanoparticles by heavy metal ions. *Chem.—Eur. J.* **2011**, *17*, 14611–14617.
- (69) Deng, R.; Xie, X.; Vendrell, M.; Chang, Y.-T.; Liu, X. Intracellular glutathione detection using MnO<sub>2</sub>-nanosheet-modified upconversion nanoparticles. *J. Am. Chem. Soc.* **2011**, *133*, 20168–20171.
- (70) Liu, C.; Wang, Z.; Jia, H.; Li, Z. Efficient fluorescence resonance energy transfer between upconversion nanophosphors and graphene oxide: a highly sensitive biosensing platform. *Chem. Commun.* **2011**, *47*, 4661–4663.